

KÄRCHER

makes a difference



OUTSTANDING SWEEPING RESULTS.

An easy and modern ride-on sweeper.



Individual flexibility for your configuration

The KM 125/130 R with hydraulic high container emptying can be emptied up to 61". A wide range of accessories is available for individual configuration. With standard sweeping crescent side brush, cleaning performance is increased when cornering and in particular when sweeping out corners or turning. Available options include flashing beacon, protective roof, seat belt, Home Base and much more.

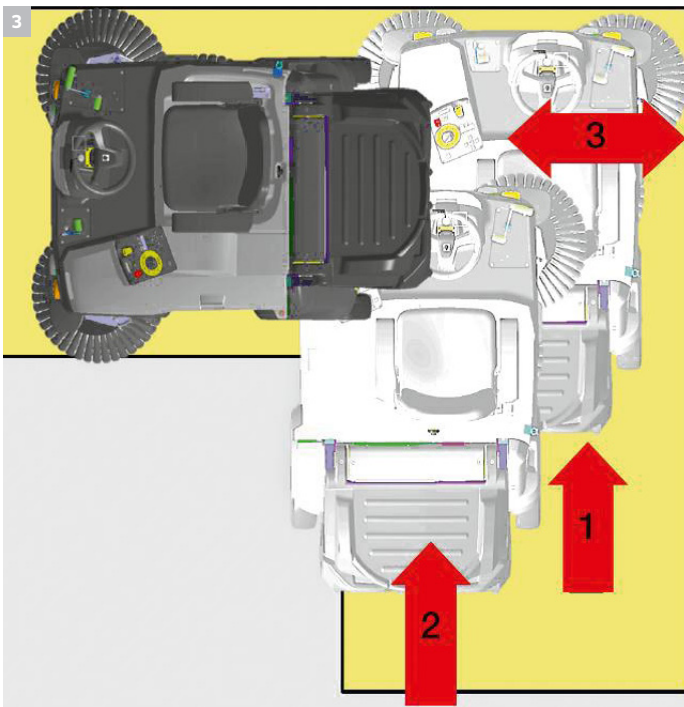

1 Emission-free battery power
The environmentally-friendly battery drive can be used both indoors and outdoors.

2 High container emptying
Convenient hydraulic emptying up to 61°. The waste container tilts back and protects the operator from unnecessary dust impact. So, there is no contact with waste.

3 Dynamic Sweeping
The Dynamic Sweeping concept enables corners to be swept out in only 3 passes due to the position of the roller brush on the rear axle - without sweeping crescent side brush.

4 Dust-free operation
The KM 125/300 R features a highly effective, fully automatic filter cleaning system called Tact. A compact, nano-coated polyester filter utilizes pulses of pressurized air for deep cleaning during operation, resulting in optimal cleaning, long life and continuous dust-free operation.

KM 125/300 R BP



Shown with optional hard roller brushes.

User-friendly combined with efficiency.

With a working width of 67", this sweeper is a high area performance machine. Thanks to a hydraulic front-wheel drive, it turns on the spot in corridors as narrow as 6.5' and effortlessly sweeps out corners with the unique sweeping crescent brush. The main sweeper roller is positioned on the rear axle to prevent contact of the sweeping system with obstacles. A new feature is the fully automatic and permanent filter cleaning system using blasts of compressed air.



1 Highly effective and automatic Tact filter cleaning system

- Thorough filter cleaning for continuous dust-free operation.
- Automatic and permanent filter cleaning.
- Compact, nano-coated polyester filter.

2 Sweeping crescent side brush (standard)

- Perfect cleaning in corners in only one pass.
- Saves time and costs as no manual precleaning or multiple passes are necessary.
- Only activated when negotiating curves.

3 Roller brush on rear axle

- Excellent access for checking or changing the roller brush.
- Safe driving over obstacles and ramps.
- Larger roller brush diameter for easier container filling.

4 Kärcher Intelligent Key

- Assignment of user rights for machine settings.
- Programmable in 19 different languages.
- Display information includes main roller sweeper wear.

STANDARD FEATURES ON THE KM 125/130 R BP

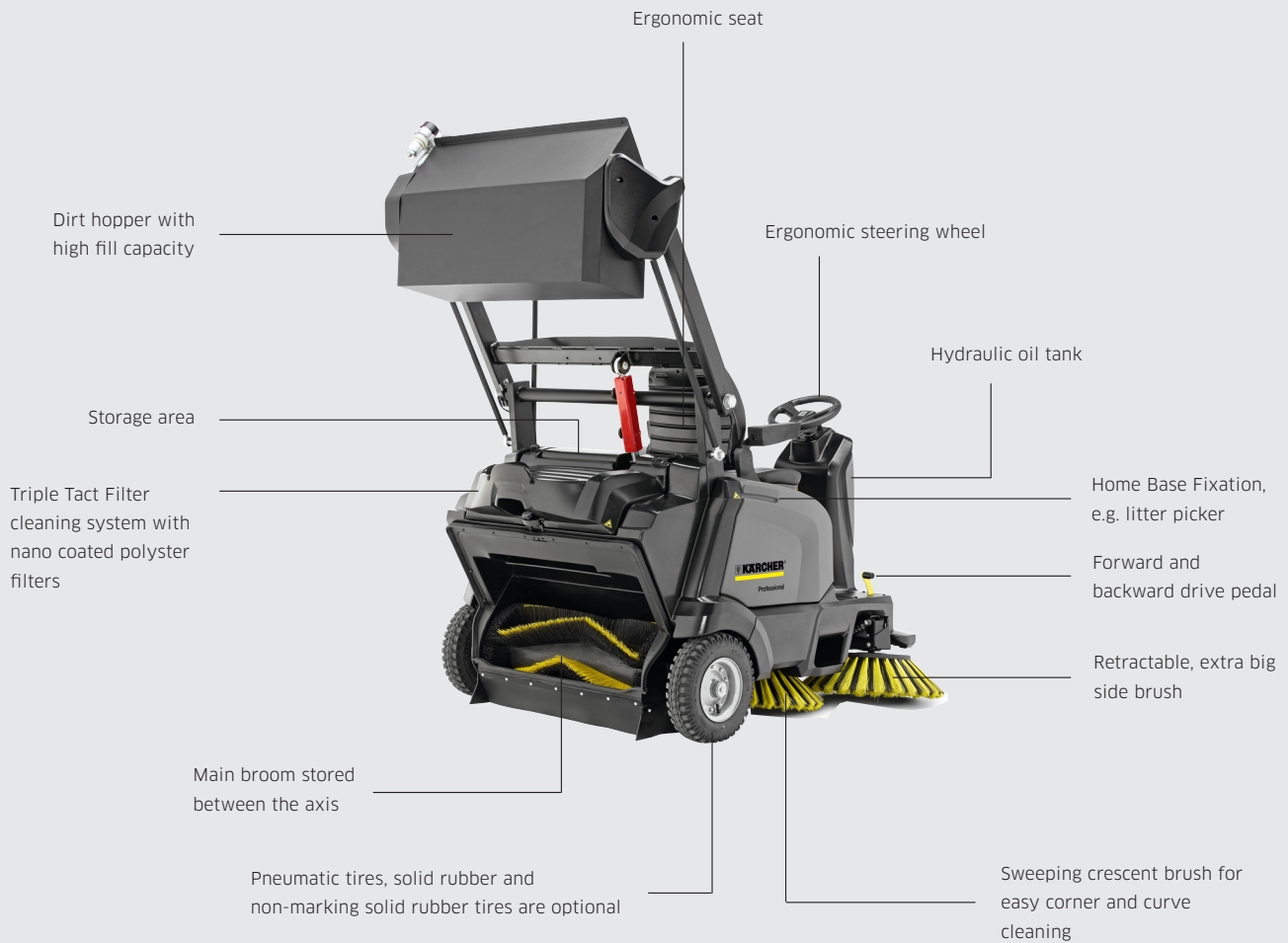

Home Base

The practical Home Base system enables a brush or litter picker to be attached securely to the machine.



Protective roof

(option, factory installed)

Protective roof compulsory in the area of high-bay warehouses. For reliable and effective protection.



Flashing beacon

(option, factory installed)

For mounting directly on the machine or protective roof. More safety for operators and others.

Technical Data and Equipment.



Shown with optional hard roller brushes.

KM 125/130 R Bp

- Easy roller brush replacement without tools
- Fully hydraulic drive and sweeping system
- Triple Tact system for ultimate filter cleaning

Technical data

Motor rating	kW	2.5
Power - Drive motor		24 V / 1,000 Watt
Max. area performance	ft² / h	32,808 (10,000 m ² /h)
Working width - main brush	inches	35 (880 mm)
Working width with 2 side brushes	inches	67 (1700 mm)
Waste container capacity	gallons	34 (130 l)
Climbing capacity	%	12
Working speed	mph	5 (8 km/h)
Filter area	ft²	59 (5.5 m ²)
Turning circle (minimum)	inches	87 (2.20 m)
Running time	hours	3-4
Weight	lbs.	2,028 (920 kg incl. Battery)
Dimensions (L x W x H)	inches	71" x 49" x 57" (1800 mm x 1250 mm x 1450 mm)

Equipment

Product	Order No.	Description
KM 125/130 R Bp	9.512-815.0	KM 125/130 R Bp (Wet)
KM 125/130 R Bp	9.512-814.0	KM 125/130 R Bp (AGM)

Equipment

Comfort seat	■	■
Pneumatic tires (2 required)	■	■
Side brush, regular	■	■
Tact filter cleaning system (3 required)	■	■
Front/Rear working lights	■	■
Main Roller Brush, regular, 35" (880 mm)	■	■
Battery, 6V, 360Ah Wet (4 required)	■	
Battery, 6V, 312Ah AGM (4 required)		■
Battery charger, 24V, 25A - for Wet & AGM batteries	■	■
Order No.	9.512-515.0	9.512-514.0

■ Included in delivery.

Accessories.



Standard Accessories (included)

Order No.	Description		
4.762-525.0	Main Roller Brush, regular, 35" (880 mm) - standard for Bp machine		
6.966-063.0	Side Brush, regular		
6.435-833.0	Pneumatic Tire, Rear (2 required)		
2.851-381.0	Comfort Seat		
4.730-004.0	TACT Filter (3 required)		
2.852-059.0	Front/Rear Working Lights		
9.512-813.0	Battery, 6V, 360Ah Wet (4 required)		for 9.512-515.0
9.512-731.0	Battery, 6V, 312Ah AGM (4 required)		for 9.512-514.0
8.623-294.0	Battery charger, 24V, 25A standard - for Wet and AGM batteries		

Optional Accessories

Order No.	Description	Image	
4.762-527.0	Main Roller Brush, hard, 35" (880 mm) (solid black color)		
4.762-526.0	Main Roller Brush, soft, 35" (880 mm) (solid yellow color)	1	
6.906-705.0	Side Brush, hard (solid black color)	2	
6.966-065.0	Side Brush, soft (solid yellow color)		
4.035-374.0	Home Base Kit		
6.435-746.0	Rubber Tire, Rear non-marking (2 required)		
6.435-439.0	Rubber Tire, Rear solid (2 required)	3	
8.641-384.0	Overhead Guard (factory install only, please allow up to heitgh weeks for delivery)	4	
8.641-386.0	Overhead Guard w/Warning Beacon (factory install only, please allow up to heitgh weeks for delivery)	5	
8.641-385.0	Warning Beacon, post mount (factory install only please allow up to heitgh weeks for delivery)	6	
8.640-208.0	Seat Belt		

Left Side Broom

Factory installed option. Please allow up to heitgh weeks for delivery.

Please contact us for more information:

Kärcher Canada Inc.

6535 Millcreek Drive
Mississauga, ON L5N 2M2

Phone +1 888 705-9444

Fax +1 800 465-6013

sales_kci@karcherna.com
www.karcher.ca